

Contact _____

E-Mail _____

Customer _____

Phone _____

Steps to Sectional Model Selection

The proper model selection for a Sectional vulcanizer depends on determining dimensions C and D (see diagram).

C - The platen length (C) is calculated by adding to the **belt manufacturer's recommended splice length**.

- 6 inches (150mm) for fabric belt
- 14 inches (355mm) for steel cord belt

D - The platen width (D) is determined by adding to the belt width.

- 6 inches (150mm) for fabric belt
- 8 inches (200mm) for steel cord belt

F - Width of the platen along the belt on bias.

To figure this multiply by:

- 1.07 for 22 degree bias angle
- 1.05 for 17 degree bias angle

Dimensions C and D represent the outside platen dimensions. Custom sizes, rectangular configurations and multiple platen arrangements are also available upon request.

BELT DETAIL:

Steel Cable or Fabric Belt _____

Max Pressure Required _____

power supply _____ Volts

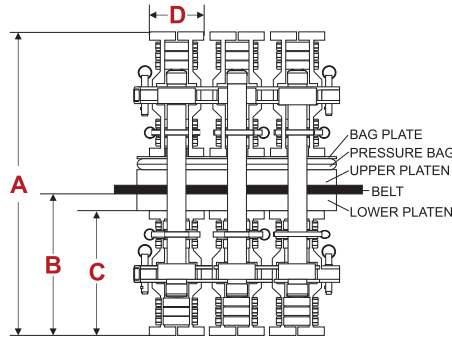

Bars	Traverse Bars Available Sizes							
	A		B		C		D	
	in	mm	in	mm	in	mm	in	mm
H200	22	559	10	248	8	197	7	178
H270	28	699	13	318	11	267	7	178
H330	33	826	13	381	12	330	6	152
H380	37	927	17	432	15	381	6.4	165

- A**= Splice Length
- B**= Belt Width
- C**= Length of platen along the belt
- D**= Width of platen measured square to belt line
- E**= Bias Angle
- F**= Width of platen along the belt on bias

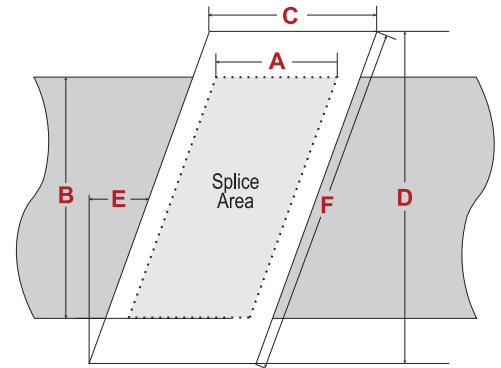

DIMENSIONS:

A= Splice Length _____

B= Belt Width _____

C= Platen Length (Splice Length +6" Fabric Belt or +14" Steelcord Belt)

D= Platen Width (Belt Width +6" Fabric Belt or +8" Steelcord Belt)

E= Bias (in Degrees) _____

F= Width of platen measured along the bias _____

Comments / Concerns / Suggestions:

Submitted By _____ Date _____